

REVERSE TRANSMITTER

SHN-RVS



A converter is in use of providing the isolation and reverse DC signal output proportional to the input signal.

- Matching a manipulating signal with the valve action.
- 1 or 2 outputs are available from 1 input.
- Contains overvoltage protection circuit.
- Transformer isolation type.

MODEL & SUFFIX CODE SELECTION

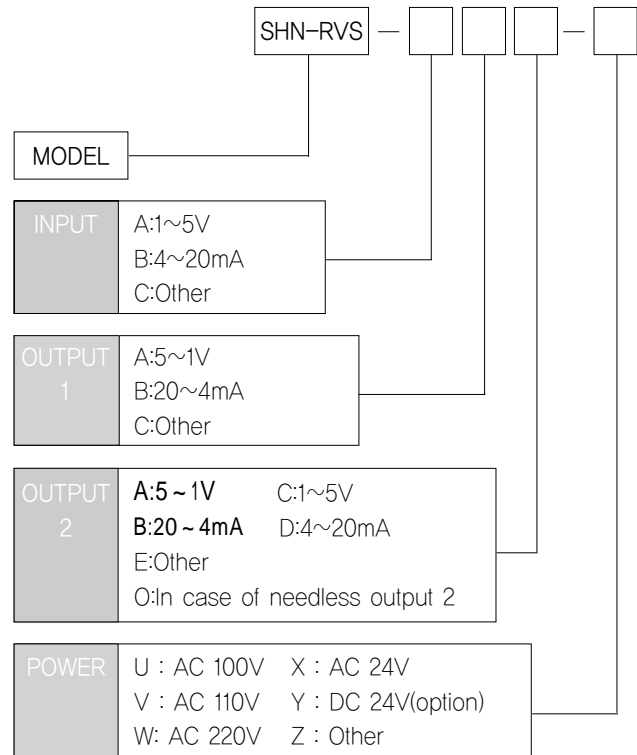

GENERAL SPECIFICATIONS

Isolation/Type	Input to output to power/Transformer isolation type		
Power Supply	AC rating $\pm 10\%$, approx. 3.5VA DC rating $\pm 10\%$, (ripple 10%)100mA		
Accuracy	$\pm 0.1\%$ (Max)		
Temp Coefficient	$\pm 0.015\%$ / $^{\circ}\text{C}$ ($\pm 0.008\%$ / $^{\circ}\text{F}$)		
Linearity	$\pm 0.02\%$ F.S		
Insulation Resistance	Greater than 100M Ω with DC 500V		
Dielectric Strength	Input - Power	AC 2500V	1 minute
	Input - Output		
	Output 1 - Output 2		
	GND - Power		
Front Adjustments	Zero and Span $\pm 5\%$		
Overrange Output	approx. $-10\% \sim 110\%$ at DC 1~5V		
Response Time	≤ 0.5 sec (0~90%)		
Operating Temperature/Humidity	$-20 \sim 60^{\circ}\text{C}$ / 90%(N,C)		
Storage Temperature/Humidity	$-20 \sim 80^{\circ}\text{C}$ / 95%(N,C)		
Dimensions	8 pin:W50xH85xD122(mm)		
	11 pin:W50xH85xD133(mm)		
Case Material	ABS Resin (black)		
Weight	about 400g		
Mounting	Wall & Rail mounting		

INPUT & OUTPUT SPECIFICATIONS

Input Impedance

Input	Impedance
4~20mA	250Ω
1~5V	1MΩ (Min)

Output Load Resistance

Output	1 Point	2 Point		Remark
	Output	Output-1	Output-2	
20 ~ 4mA	700Ω	600Ω	350Ω	(Max)
5 ~ 1V	5kΩ	5kΩ	5kΩ	(Min)

BLOCK DIAGRAM

1 Point Output

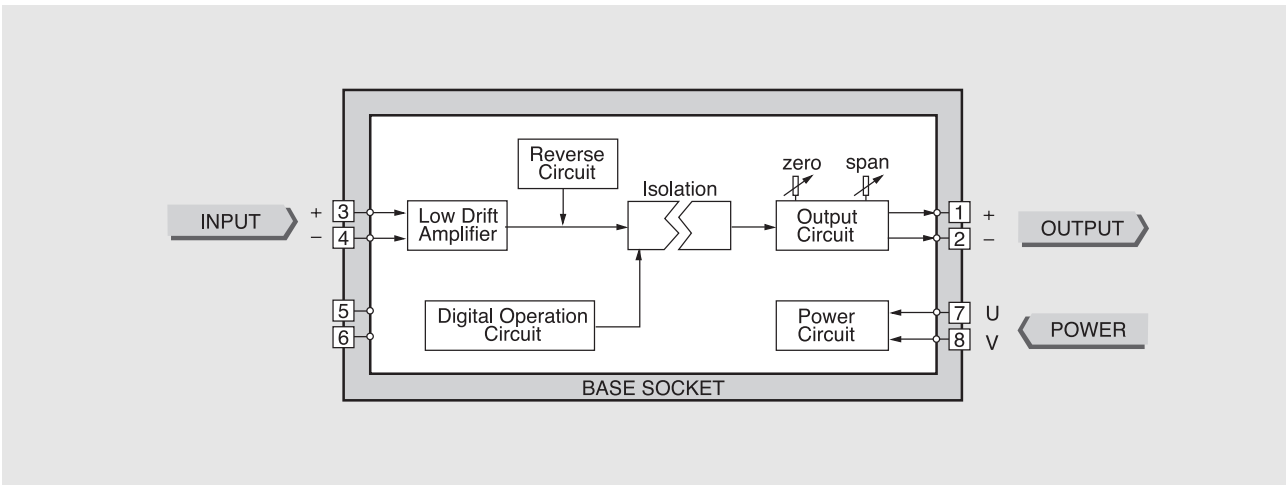

2 Point Output

