

FLOWX3 F3.00 Paddlewheel Flow Sensor

3.00

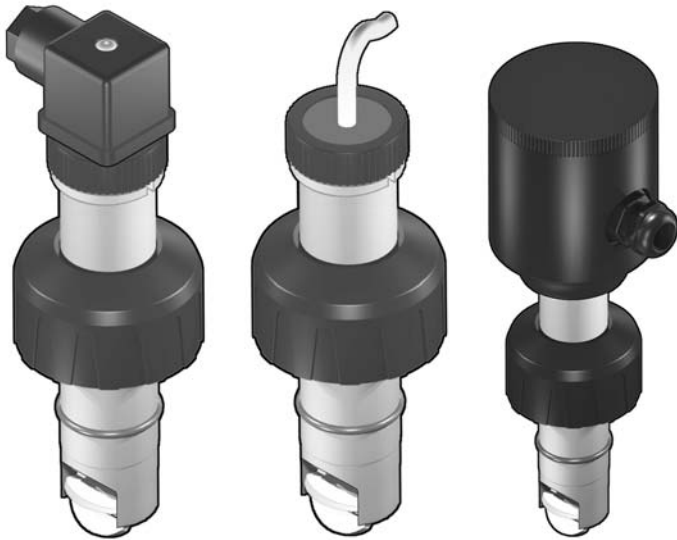

The simple and reliable paddlewheel flow sensor type F3.00 is designed for use with every kind of solid-free liquids.

The sensor can measure flow from 0.15 m/s (0.5 ft/s) producing a frequency output signal highly repeatable.

A rugged construction and a proven technology guarantee exceptional performances with little or no maintenance required.

A new electronic, with a push-pull output, is now available for a safe connection to any kind of PLC/Instrument digital input.

A specially designed family of fittings ensures an easy and quick installation into all pipe materials in sizes from DN15 to DN600 (0.5" to 24").

Main Features

- CPVC, PVDF, Brass or Stainless Steel sensor body.
- Easy insertion system.
- Different versions for remote and compact installations.
- Measurement range over 50:1.
- High chemical resistance.
- Battery powered version.
- 4-20 mA output.
- MIN alarm relay output.
- Push-Pull output for universal electrical connection.

Applications

- Water treatment and regeneration.
- Industrial wastewater treatment and recovery.
- Textile finishing.
- Water distribution.
- Processing and manufacturing industry.
- Filtration systems.
- Chemical production.
- Liquid delivery systems.
- Cooling water monitoring.
- Heat Exchangers.
- Swimming pools.
- Pump protection.

Technical Features

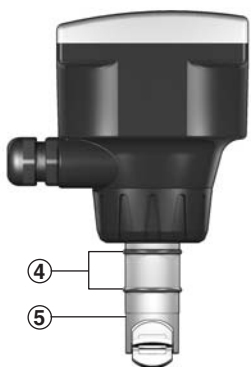

Sensor for compact installation (F3.01) with field-mount transmitter (sold separately)

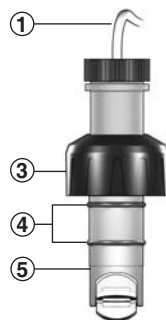

Sensor for remote installation in IP68 configuration

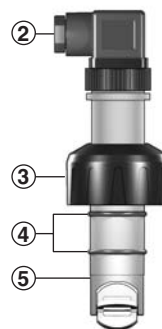

Sensor for remote installation in IP65 configuration

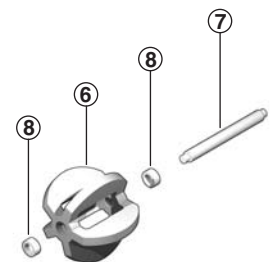

Paddlewheel system

- 1) Electrical cable: 8 m. (26.4 ft) standard
- 2) 4 pole cable plug according to DIN 43650-B/ISO 6952
- 3) PVC cap for installation into fittings
- 4) O-Ring seals available in EPDM or FPM
- 5) CPVC, PVDF, Brass or Stainless Steel sensor body
- 6) ECTFE (Halar®) Open-cell rotor
- 7) Ceramic shaft
- 8) Ceramic bearings

Halar® is a registered trademark of Ausimont-Solvay.

Operating principle

The flow sensor consists of a transducer and a five-blade open cell paddlewheel using insertion technology. The paddlewheel is equipped with a permanent magnet integrated into each blade. As the magnet passes close to the transducer a pulse is generated.

When liquid flows into the pipe, the paddlewheel is set in rotation producing a square wave output signal. The frequency is proportional to the flow velocity. The sensor is installed into the pipe using a wide range of insertion type fittings supplied by the flow sensor manufacturer.

Engineering Data

- The flow sensor is available with Hall effect transducer (standard) and Coil effect transducer (battery operated).
- The Hall sensor operates with a power supply from 5 to 24 VDC @ < 30 mA.
- The Coil sensor operates with a power supply from 3 to 5 VDC @ < 10 μ A or with a 3.6V Lithium Battery.
- The standard output is a square wave with a frequency of 45 Hz per m/s (13.7 Hz per ft/s) nominal.
- The output signal is provided directly via electric cable or via a cable plug according to DIN 43650-B/ISO 6952. Supplied cable is standard 8 m (26.4 ft) long, with a maximum length of 300 m (990 ft) for Hall sensor and 16 m (52.8 ft) for Coil sensor
- In the versions with 4-20 mA or MIN alarm output, an additional IP65 housing is plugged onto the sensor. Output signals are available on a terminal strip inside via a PG11 cable gland.
- The sensor F3.30 with 4-20 mA output and the sensor F3.15 with MIN alarm output require a power supply from 12 to 24 VDC.
- The nominal measuring range is from 0.15 to 8 m/s (0.5 to 25 ft/s).

Connections to FlowX3 Instruments

FLOWX3 Sensors	FLOW X3 Instruments							PLC/ other brand
	F9.00	F9.01	F9.02	F9.03	F9.20	F9.50	F9.51	
F3.00.H	■	■	■	■		■	■	
F3.00.C					■			
F3.01.H	■	■	■	■		■	■	
F3.01.C					■			
F3.00.P								■
F3.15.H*		■	■	■		■	■	
F3.30.H*								

* with Output Kit mounted.

Dimensions

F3.00 IP68 Remote Sensor

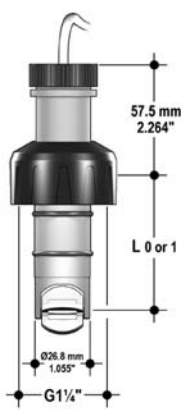

F3.00 IP65 Remote Sensor

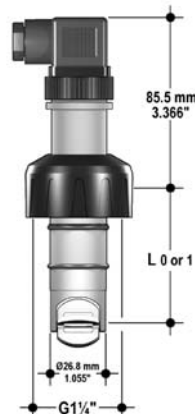

F3.01 Compact Sensor

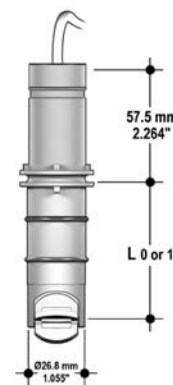

F3.01 Compact Sensor + Transmitter (sold separately)

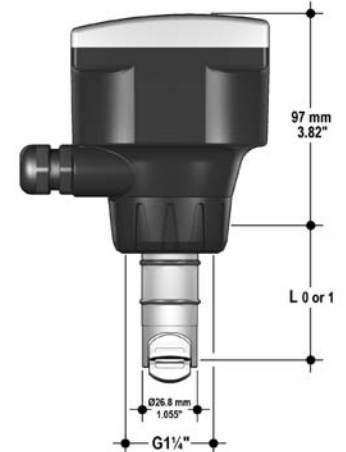

Sensor length:
L0 = 68.3 mm (2.69")
L1 = 98.5 mm (3.88")

Installation Fittings

Please refer to Installation Fittings section for more details and a complete listing of items.

	Type	Description
	Plastic Tees	Size: D20 to D50 (0.5" to 1.5") Materials: PVC, CPVC, PP, PVDF
	CPVC Clamp Saddles	Size: D63 to D225 (2" to 8") Insert materials: CPVC, PVDF
	PP Clamp Saddles	Size: D250 to D315 (10" to 12") Insert material: CPVC
	PVC Wafer Fittings	Size: D280 and D315 (10" and 12") Insert material: CPVC
	GR-PP Wafer Fittings	Size: D280 and D315 (10" and 12") Insert material: CPVC
	Plastic Weld-on Adapters	Size: D63 to D315 Materials: PVC, CPVC, PP, PE
	316L SS Tees	Size: D25 to D40 BSP Female Threaded
	Metal Strap-on Saddles	Size: DN80 to DN450 Insert material: CPVC Special order for other sizes for Wet Tap Installation Special order for bigger sizes
	316L SS Weld-on Adapters	Size: D50 to D600 (1.5" to 24")

Installation Guidelines

Different pipe configurations and obstacles in the flow line such as valves, elbows, pipe bends and strainers create variations on the flow profile.

- The six most common installation configurations are shown to help in selecting the best location in the pipeline for paddlewheel flow sensor.

- For more information, please refer to EN ISO 5167-1.

- Always maximize distance between flow sensors and pumps.

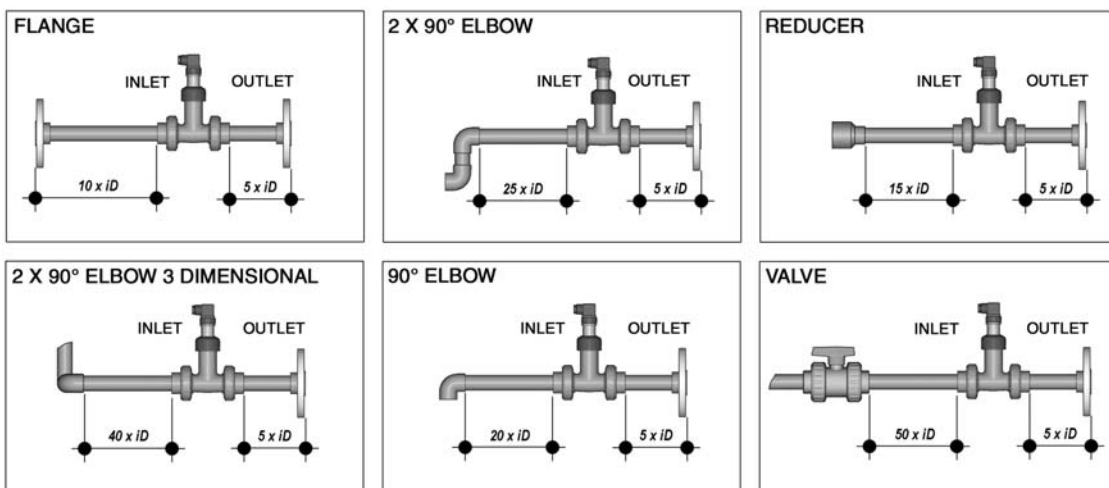

Mounting Positions

Make sure the pipeline is always full.

- Horizontal pipe runs:

Fig.1 : installation with no sediments present

Fig.2 : installation with no air bubbles present

Fig.3 : installation if sediments or air bubbles may be present.

- Vertical pipe runs:

Install sensor in any orientation.

Upward flow is preferred to ensure full pipe.

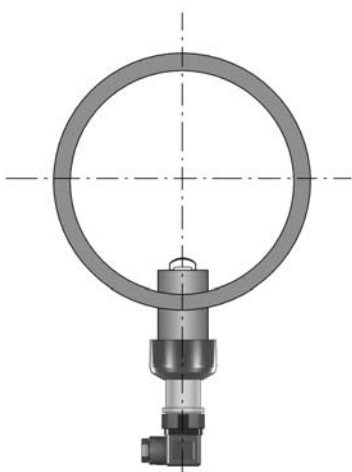

Fig. 1

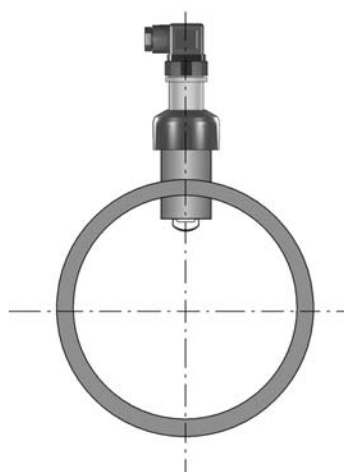

Fig. 2

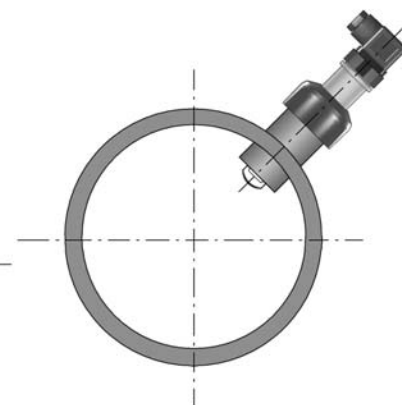
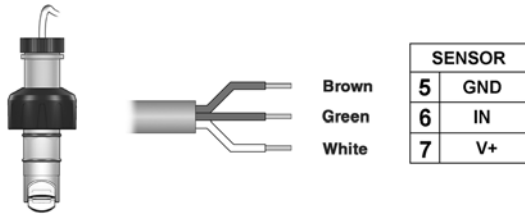
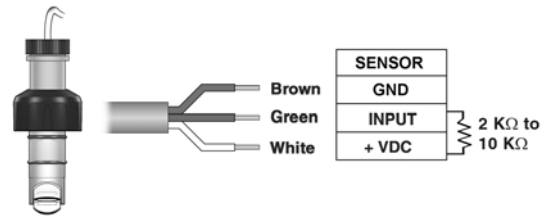

Fig. 3

Wiring F3.00.H IP68 Sensor Connection to FLOWX3 Instruments



F3.00.H IP68 Sensor Connection to Other Brand Instruments



2 K Ω to 10 K Ω Pull-up resistor may be required.

F3.00.H IP65 Sensor Connection to FLOWX3 Instruments

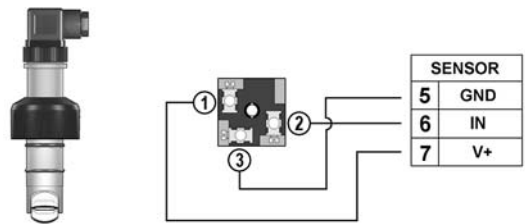

F3.00.H IP65 Sensor Connection to Other Brand Instruments

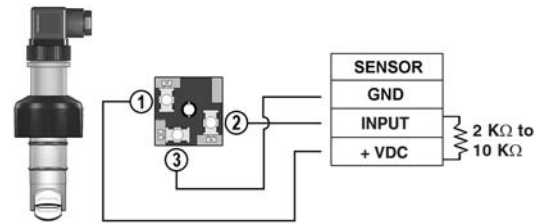

2 K Ω to 10 K Ω Pull-up resistor may be required.

F3.00.C IP68 Sensor Connection to FLOWX3 Instruments

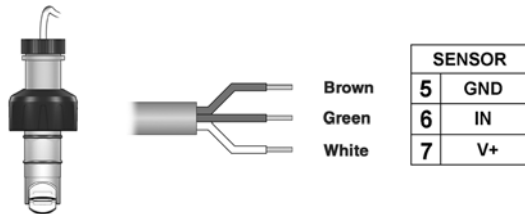

F3.00.C IP68 Sensor Connection to Other Brand Instruments

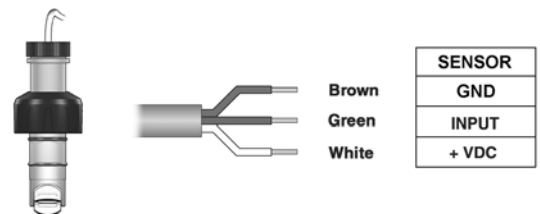

Pull-up resistor is never required.

F3.00.C IP65 Sensor Connection to FLOWX3 Instruments

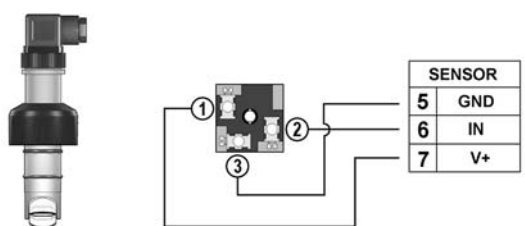

F3.00.C IP65 Sensor Connection to Other Brand Instruments

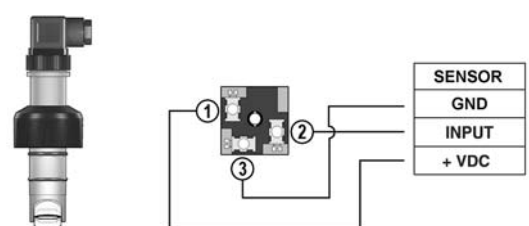

Pull-up resistor is never required.

F3.00.P IP68 Sensor Connection to Other Brand Instruments

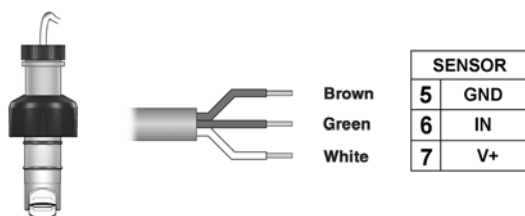

F3.00.P.IP65 Sensor Connection to Other Brand Instruments

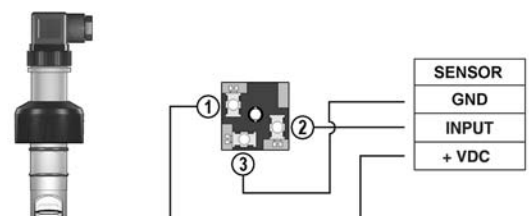

Pull-up resistor is never required.

Technical Data

General (for F3.00.H, F3.00.C and F3.00.P)

- Pipe Size Range: DN15 to DN600 (0.5" to 24"). Please refer to Installation Fittings section for more details.
- Flow Rate Range: 0.15 to 8 m/s (0.5 to 25 ft./s).
- Linearity: $\pm 0.75\%$ of full scale.
- Repeatability: $\pm 0.5\%$ of full scale.
- Minimum Reynolds Number Required: 4500.
- Enclosure: IP68 or IP65.
- Wetted Materials:
 - Sensor Body: CPVC, PVDF, Brass or 316L SS
 - O-rings: EPDM or FPM
 - Rotor: ECTFE (Halar®)
 - Shaft: Ceramic (Al₂O₃)
 - Bearings: Ceramic (Al₂O₃).

Specific for F3.00.H

- Supply voltage: 5 to 24 VDC $\pm 10\%$ regulated.
- Supply current: < 30 mA @ 24 VDC.
- Output signal:
 - square wave.
 - frequency: 45 Hz per m/s nominal (13.7 Hz per ft/s nominal).
 - type: transistor NPN open collector.
 - Output current: 10 mA max.
- Cable length: 8 m (26.4 ft) standard, 300 m (990 ft) maximum.

Specific for F3.00.C

- Supply voltage: 3 to 5 VDC regulated or 3.6 Volt Lithium battery.
- Supply current: < 10 μ A max.
- Output signal:
 - square wave.
 - frequency: 45 Hz per m/s nominal (13.7 Hz per ft/s nominal).
 - Min. input impedance: 100 k Ω .
- Cable length: 8 m (26.4 ft) standard, 16 m (52.8 ft) maximum.

Specific for F3.00.P

- Supply voltage: 12 to 24 VDC $\pm 10\%$ regulated.
- Supply current: < 30 mA @ 24 VDC
- Output signal:
 - square wave.
 - frequency: 45 Hz per m/s nominal (13.7 Hz per ft/s nominal).
 - type: Push-Pull (for connection to NPN and PNP inputs).
 - Output current: 20 mA max.
- Cable length: 8 m (26.4 ft) standard, 300 m (990 ft) maximum.

Standards & Approvals

- Manufactured under ISO 9001 (Quality).
- Manufactured under ISO 14001 (Environmental Management).
- CE.

Maximum Operating Pressure / Temperature (25 years lifetime)

F3.00.H or F3.00.P Sensor

- CPVC body:
 - 10 bar (145 psi) @ 25°C (77°F)
 - 1,5 bar (22 psi) @ 80°C (176°F).
- PVDF body:
 - 10 bar (145 psi) @ 25°C (77°F)
 - 2,5 bar (36 psi) @ 100°C (212°F).
- Brass or SS body:
 - 25 bar (363 psi) @ 120°C (248°F).

F3.00.C Sensor

- CPVC body:
 - 10 bar (145 psi) @ 25°C (77°F)
 - 1,5 bar (22 psi) @ 80°C (176°F).
- PVDF body:
 - 10 bar (145 psi) @ 25°C (77°F)
 - 2,5 bar (36 psi) @ 100°C (212°F).
- Brass or SS body:
 - 25 bar (363 psi) @ 100°C (212°F).

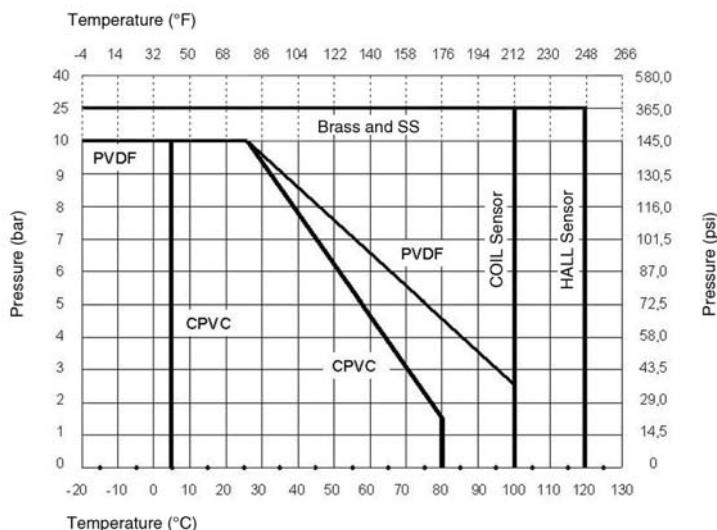

Output Devices **K315 - Frequency Output & MIN alarm KIT**

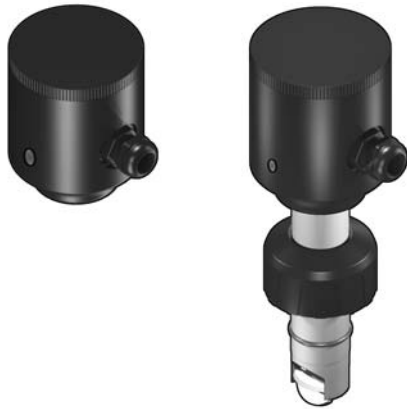

This Kit consists of an additional IP65 housing plugged on the sensor. It is equipped with an open collector frequency output and a mechanical SPDT contact.

The MIN alarm set-point can be freely set by a potentiometer from 0.15 to 1 m/s (0.5 to 3.3 ft/s).

When the flow velocity drops below the adjusted limit the relay output opens and the Local Status Indicator changes colour. It has been designed to protect a pump from running dry or pumping against a closed valve in the main pipeline.

Main Features

- Highly visible Local Bicolour Status Indicator.
- Easy and quick threshold regulation.
- Open collector frequency output.
- Relay output mechanical SPDT.

Applications

- Pump protection.
- Industrial water and wastewater treatment.
- Cooling water systems.
- Swimming pools.

Dimensions

KIT K315



F3.15 Sensor with O.C. output & MIN alarm

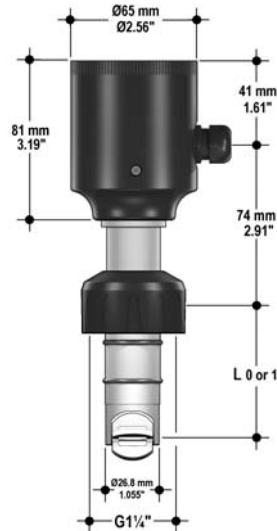

Sensor length:

L0 = 68.3 mm (2.69")

L1 = 98.5 mm (3.88")

Wiring and Operation

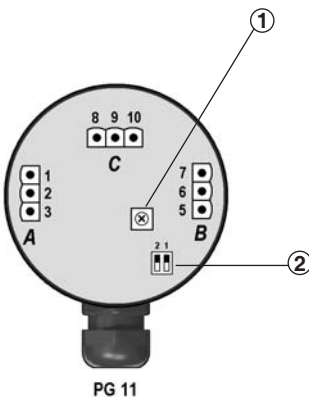

Power Supply

1	+12-24 VDC
2	FREQ. OUTPUT
3	GND

Sensor

SENSOR	
7	V+
6	IN
5	GND

Relay Output

RELAY	
8	NO
9	NC
10	COM

The output module is characterized by two operation modes:

- Calibration mode:

Switch 1 is in OFF position and the MIN. Set-point is fixed by acting on the trimmer.

- Operative mode

Switch 1 is in ON position and the module ready to work. Switch 2 can be used to select the most suitable switch delay (3 seconds or 10 seconds).

1) Calibration trimmer for MIN alarm set-point.

2) Setting switches.

Output Devices

Technical Data

- Associated Flow Sensor: Hall effect (F3.01.H.XX Compact version).
- Supply voltage: 12 to 24 VDC \pm 10% regulated.
- Output signal:
 - square wave
 - frequency: 45Hz per m/s nominal (13.7 Hz per ft/s nominal)
 - type: transistor NPN open collector
 - Output current: 10 mA max.
- Relay Output: mechanical SPDT contact, 3A @ 30 VDC, 3A @ 250 VAC resistive load.
- Flow trip point: 0.15 to 1 m/s (0.5 to 3 ft/s) freely adjustable.

- Local Status Indicator:
 - GREEN Led = Flow
 - RED Led = No Flow.
- Enclosure: IP65.
- Operating temperature: 0°C to 60°C (32°F to 140°F).
- Relative humidity: 0 to 95% non-condensing.
- Housing material: PVC.

Standards & Approvals

- Manufactured under ISO 9001 (Quality).
- Manufactured under ISO 14001 (Environmental Management).
- CE.

K330 – 4-20 mA Output KIT



This Kit consists of an additional IP65 housing plugged on the sensor. It is a blind transmitter designed to convert the signal from the sensor into a 4-20 mA signal for long distance transmission.

Main Features

- Easy 4-20 mA output calibration.
- Three wire output technology.

Applications

- Flow control and monitoring.
- Water treatment.
- Industrial wastewater treatment and recovery.
- Water regeneration plant.
- Processing and manufacturing industry.
- Water distribution.

Dimensions

K330 KIT

F3.30 Sensor with 4-20 mA Output

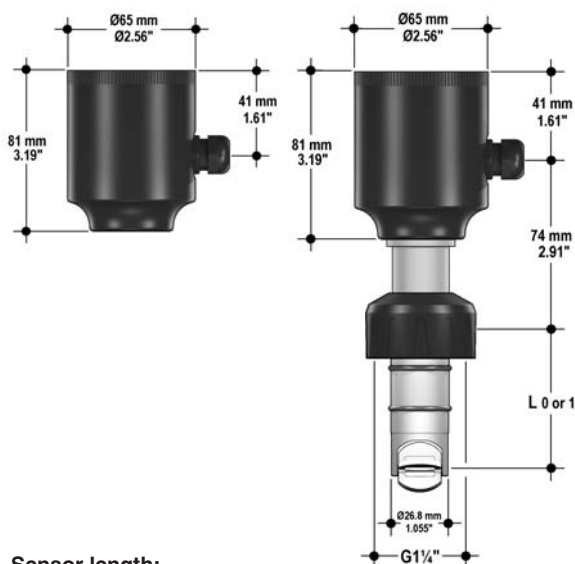

Sensor length:
 L0 = 68.3 mm (2.69")
 L1 = 98.5 mm (3.88")

Output Devices

Wiring and Operation

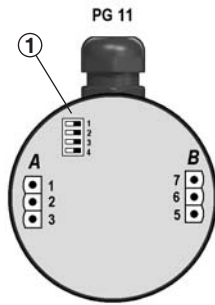

Power Supply	
A	1 +12-24 VDC
	2 4-20 mA OUTPUT
	3 GND

Sensor	
B	7 V+
	6 IN
	5 GND

1) Calibration switch.

The full scale range, corresponding to 4-20 mA output, is set by means of switches 2, 3 and 4.

Switch 1 is used to set a filter on the current output.

Technical Data

- Associated Flow Sensor: Hall effect (F3.01.H.XX Compact version).
- Supply voltage: 12 to 24 VDC \pm 10% regulated
- Supply current: < 50 mA.
- Output signal: 4 to 20 mA, adjustable.
- Max load impedance: 800 Ω @ 24 VDC, 300 Ω @ 12 VDC.
- Enclosure: IP65.
- Operating temperature: 0°C to 60°C (32°F to 140°F).
- Relative humidity: 0 to 95% non-condensing.
- Housing material: PVC.

Standards & Approvals

- Manufactured under ISO 9001 (Quality).
- Manufactured under ISO 14001 (Environmental Management).
- CE.

Installation

The K315 and K330 Kits can be ordered directly mounted on top of the flow sensor or separately and then simply installed on the proper sensor.

Please refer to Ordering Data section for a complete listing of part numbers.

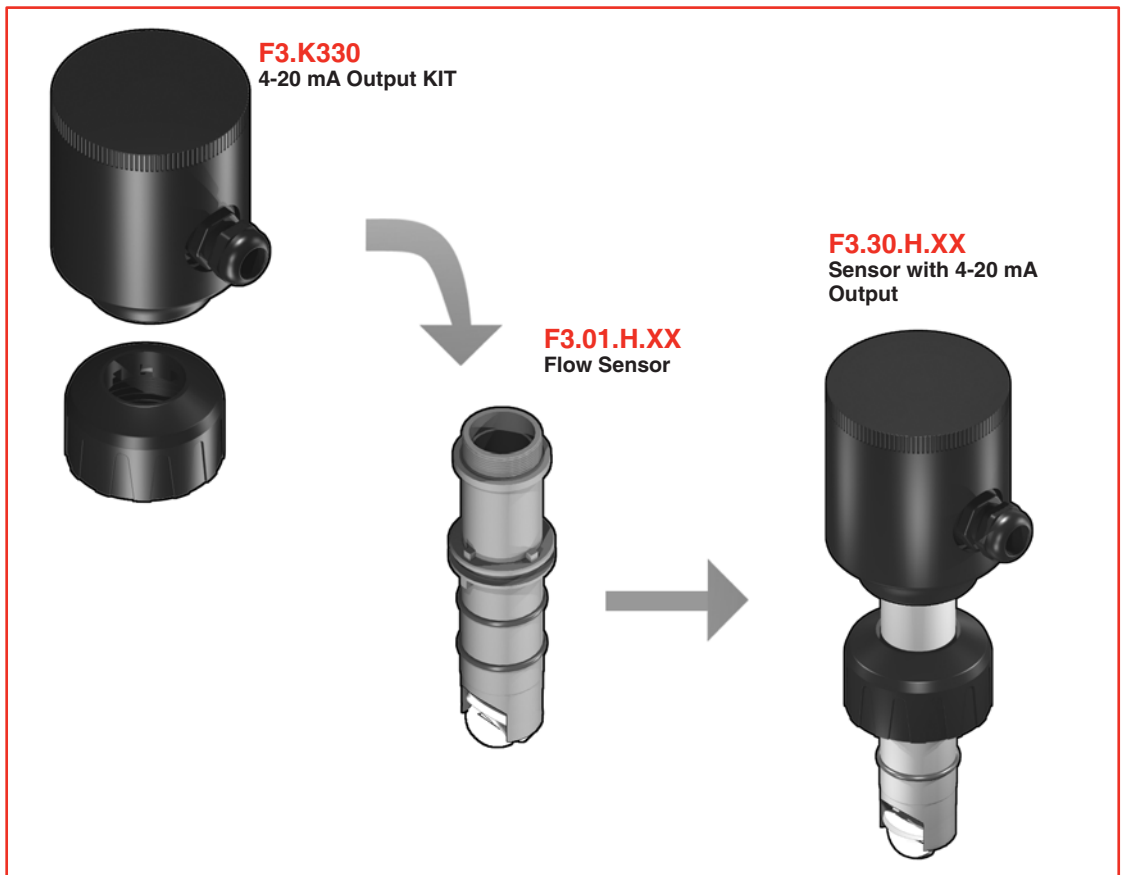
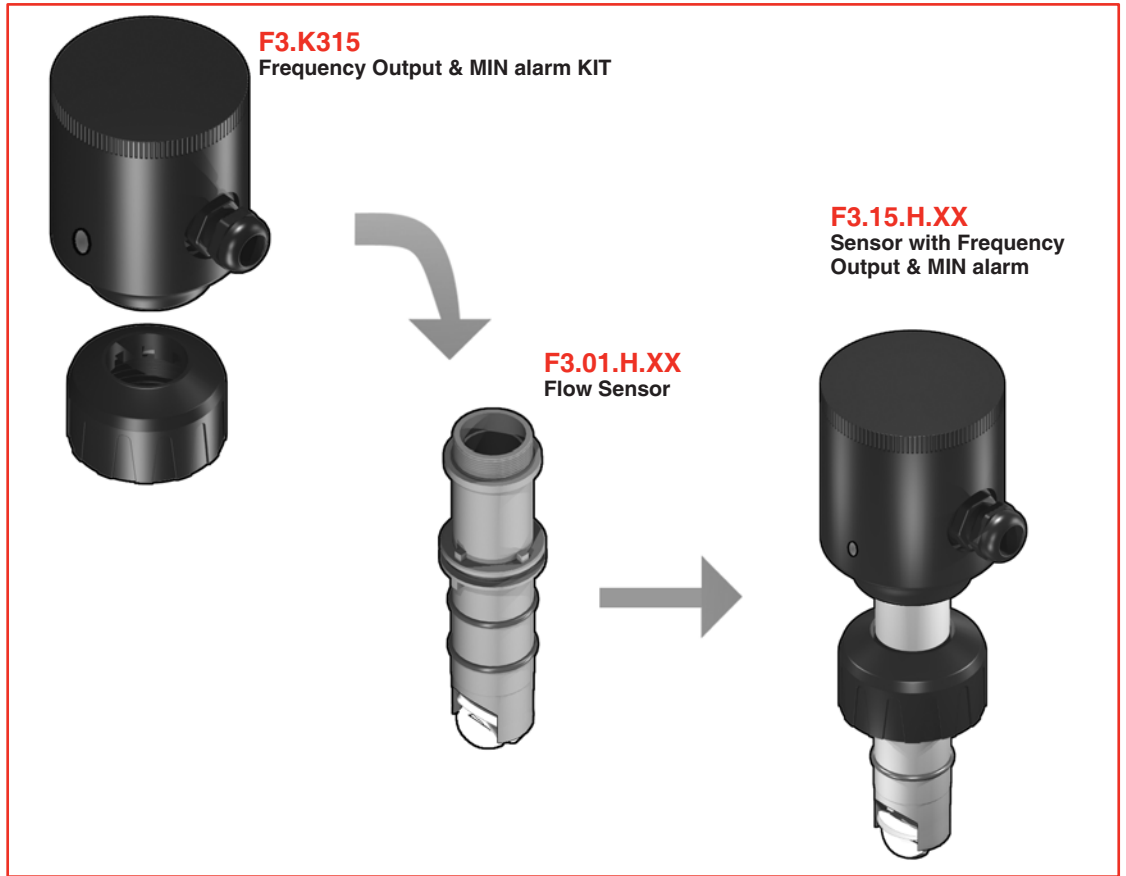

Ordering Data

FLOWX3 F3.00.H.XX (Remote version)

Part No.	Version	Power supply	Length	Body	O-rings	Enclosure
F3.00.H.01	Hall	5 - 24 VDC	L0	C-PVC	EPDM	IP68
F3.00.H.02	Hall	5 - 24 VDC	L0	C-PVC	FPM	IP68
F3.00.H.03	Hall	5 - 24 VDC	L1	C-PVC	EPDM	IP68
F3.00.H.04	Hall	5 - 24 VDC	L1	C-PVC	FPM	IP68
F3.00.H.05	Hall	5 - 24 VDC	L0	PVDF	EPDM	IP68
F3.00.H.06	Hall	5 - 24 VDC	L0	PVDF	FPM	IP68
F3.00.H.07	Hall	5 - 24 VDC	L1	PVDF	EPDM	IP68
F3.00.H.08	Hall	5 - 24 VDC	L1	PVDF	FPM	IP68
F3.00.H.09	Hall	5 - 24 VDC	L0	316L SS	EPDM	IP68
F3.00.H.10	Hall	5 - 24 VDC	L0	316L SS	FPM	IP68
F3.00.H.11	Hall	5 - 24 VDC	L1	316L SS	EPDM	IP68
F3.00.H.12	Hall	5 - 24 VDC	L1	316L SS	FPM	IP68
F3.00.H.25	Hall	5 - 24 VDC	L0	BRASS	EPDM	IP68
F3.00.H.26	Hall	5 - 24 VDC	L0	BRASS	FPM	IP68
F3.00.H.27	Hall	5 - 24 VDC	L1	BRASS	EPDM	IP68
F3.00.H.28	Hall	5 - 24 VDC	L1	BRASS	FPM	IP68
F3.00.H.13	Hall	5 - 24 VDC	L0	C-PVC	EPDM	IP65
F3.00.H.14	Hall	5 - 24 VDC	L0	C-PVC	FPM	IP65
F3.00.H.15	Hall	5 - 24 VDC	L1	C-PVC	EPDM	IP65
F3.00.H.16	Hall	5 - 24 VDC	L1	C-PVC	FPM	IP65
F3.00.H.17	Hall	5 - 24 VDC	L0	PVDF	EPDM	IP65
F3.00.H.18	Hall	5 - 24 VDC	L0	PVDF	FPM	IP65
F3.00.H.19	Hall	5 - 24 VDC	L1	PVDF	EPDM	IP65
F3.00.H.20	Hall	5 - 24 VDC	L1	PVDF	FPM	IP65
F3.00.H.21	Hall	5 - 24 VDC	L0	316L SS	EPDM	IP65
F3.00.H.22	Hall	5 - 24 VDC	L0	316L SS	FPM	IP65
F3.00.H.23	Hall	5 - 24 VDC	L1	316L SS	EPDM	IP65
F3.00.H.24	Hall	5 - 24 VDC	L1	316L SS	FPM	IP65
F3.00.H.29	Hall	5 - 24 VDC	L0	BRASS	EPDM	IP65
F3.00.H.30	Hall	5 - 24 VDC	L0	BRASS	FPM	IP65
F3.00.H.31	Hall	5 - 24 VDC	L1	BRASS	EPDM	IP65
F3.00.H.32	Hall	5 - 24 VDC	L1	BRASS	FPM	IP65

Ordering Data

FLOWX3 F3.00.C.XX (Remote version)

Part No.	Version	Power supply	Length	Body	O-rings	Enclosure
F3.00.C.01	Coil	3 - 5 VDC	L0	C-PVC	EPDM	IP68
F3.00.C.02	Coil	3 - 5 VDC	L0	C-PVC	FPM	IP68
F3.00.C.03	Coil	3 - 5 VDC	L1	C-PVC	EPDM	IP68
F3.00.C.04	Coil	3 - 5 VDC	L1	C-PVC	FPM	IP68
F3.00.C.05	Coil	3 - 5 VDC	L0	PVDF	EPDM	IP68
F3.00.C.06	Coil	3 - 5 VDC	L0	PVDF	FPM	IP68
F3.00.C.07	Coil	3 - 5 VDC	L1	PVDF	EPDM	IP68
F3.00.C.08	Coil	3 - 5 VDC	L1	PVDF	FPM	IP68
F3.00.C.09	Coil	3 - 5 VDC	L0	316L SS	EPDM	IP68
F3.00.C.10	Coil	3 - 5 VDC	L0	316L SS	FPM	IP68
F3.00.C.11	Coil	3 - 5 VDC	L1	316L SS	EPDM	IP68
F3.00.C.12	Coil	3 - 5 VDC	L1	316L SS	FPM	IP68
F3.00.C.25	Coil	3 - 5 VDC	L0	BRASS	EPDM	IP68
F3.00.C.26	Coil	3 - 5 VDC	L0	BRASS	FPM	IP68
F3.00.C.27	Coil	3 - 5 VDC	L1	BRASS	EPDM	IP68
F3.00.C.28	Coil	3 - 5 VDC	L1	BRASS	FPM	IP68
F3.00.C.13	Coil	3 - 5 VDC	L0	C-PVC	EPDM	IP65
F3.00.C.14	Coil	3 - 5 VDC	L0	C-PVC	FPM	IP65
F3.00.C.15	Coil	3 - 5 VDC	L1	C-PVC	EPDM	IP65
F3.00.C.16	Coil	3 - 5 VDC	L1	C-PVC	FPM	IP65
F3.00.C.17	Coil	3 - 5 VDC	L0	PVDF	EPDM	IP65
F3.00.C.18	Coil	3 - 5 VDC	L0	PVDF	FPM	IP65
F3.00.C.19	Coil	3 - 5 VDC	L1	PVDF	EPDM	IP65
F3.00.C.20	Coil	3 - 5 VDC	L1	PVDF	FPM	IP65
F3.00.C.21	Coil	3 - 5 VDC	L0	316L SS	EPDM	IP65
F3.00.C.22	Coil	3 - 5 VDC	L0	316L SS	FPM	IP65
F3.00.C.23	Coil	3 - 5 VDC	L1	316L SS	EPDM	IP65
F3.00.C.24	Coil	3 - 5 VDC	L1	316L SS	FPM	IP65
F3.00.C.29	Coil	3 - 5 VDC	L0	BRASS	EPDM	IP65
F3.00.C.30	Coil	3 - 5 VDC	L0	BRASS	FPM	IP65
F3.00.C.31	Coil	3 - 5 VDC	L1	BRASS	EPDM	IP65
F3.00.C.32	Coil	3 - 5 VDC	L1	BRASS	FPM	IP65

Ordering Data

FLOWX3 F3.00.P.XX (Remote version)

Part No.	Version	Power supply	Length	Body	O-rings	Enclosure
F3.00.P.01	Push-Pull	12 -24 VDC	L0	C-PVC	EPDM	IP68
F3.00.P.02	Push-Pull	12 -24 VDC	L0	C-PVC	FPM	IP68
F3.00.P.03	Push-Pull	12 -24 VDC	L1	C-PVC	EPDM	IP68
F3.00.P.04	Push-Pull	12 -24 VDC	L1	C-PVC	FPM	IP68
F3.00.P.05	Push-Pull	12 -24 VDC	L0	PVDF	EPDM	IP68
F3.00.P.06	Push-Pull	12 -24 VDC	L0	PVDF	FPM	IP68
F3.00.P.07	Push-Pull	12 -24 VDC	L1	PVDF	EPDM	IP68
F3.00.P.08	Push-Pull	12 -24 VDC	L1	PVDF	FPM	IP68
F3.00.P.09	Push-Pull	12 -24 VDC	L0	316L SS	EPDM	IP68
F3.00.P.10	Push-Pull	12 -24 VDC	L0	316L SS	FPM	IP68
F3.00.P.11	Push-Pull	12 -24 VDC	L1	316L SS	EPDM	IP68
F3.00.P.12	Push-Pull	12 -24 VDC	L1	316L SS	FPM	IP68
F3.00.P.25	Push-Pull	12 -24 VDC	L0	BRASS	EPDM	IP68
F3.00.P.26	Push-Pull	12 -24 VDC	L0	BRASS	FPM	IP68
F3.00.P.27	Push-Pull	12 -24 VDC	L1	BRASS	EPDM	IP68
F3.00.P.28	Push-Pull	12 -24 VDC	L1	BRASS	FPM	IP68
F3.00.P.13	Push-Pull	12 -24 VDC	L0	C-PVC	EPDM	IP65
F3.00.P.14	Push-Pull	12 -24 VDC	L0	C-PVC	FPM	IP65
F3.00.P.15	Push-Pull	12 -24 VDC	L1	C-PVC	EPDM	IP65
F3.00.P.16	Push-Pull	12 -24 VDC	L1	C-PVC	FPM	IP65
F3.00.P.17	Push-Pull	12 -24 VDC	L0	PVDF	EPDM	IP65
F3.00.P.18	Push-Pull	12 -24 VDC	L0	PVDF	FPM	IP65
F3.00.P.19	Push-Pull	12 -24 VDC	L1	PVDF	EPDM	IP65
F3.00.P.20	Push-Pull	12 -24 VDC	L1	PVDF	FPM	IP65
F3.00.P.21	Push-Pull	12 -24 VDC	L0	316L SS	EPDM	IP65
F3.00.P.22	Push-Pull	12 -24 VDC	L0	316L SS	FPM	IP65
F3.00.P.23	Push-Pull	12 -24 VDC	L1	316L SS	EPDM	IP65
F3.00.P.24	Push-Pull	12 -24 VDC	L1	316L SS	FPM	IP65
F3.00.P.29	Push-Pull	12 -24 VDC	L0	BRASS	EPDM	IP65
F3.00.P.30	Push-Pull	12 -24 VDC	L0	BRASS	FPM	IP65
F3.00.P.31	Push-Pull	12 -24 VDC	L1	BRASS	EPDM	IP65
F3.00.P.32	Push-Pull	12 -24 VDC	L1	BRASS	FPM	IP65

Ordering Data

FLOWX3 F3.01.X.XX (Compact version)

Part No.	Version	Power supply	Length	Body	O-rings	Enclosure
F3.01.H.01	Hall	5 - 24 VDC	L0	C-PVC	EPDM	IP68
F3.01.H.02	Hall	5 - 24 VDC	L0	C-PVC	FPM	IP68
F3.01.H.03	Hall	5 - 24 VDC	L1	C-PVC	EPDM	IP68
F3.01.H.04	Hall	5 - 24 VDC	L1	C-PVC	FPM	IP68
F3.01.H.05	Hall	5 - 24 VDC	L0	PVDF	EPDM	IP68
F3.01.H.06	Hall	5 - 24 VDC	L0	PVDF	FPM	IP68
F3.01.H.07	Hall	5 - 24 VDC	L1	PVDF	EPDM	IP68
F3.01.H.08	Hall	5 - 24 VDC	L1	PVDF	FPM	IP68
F3.01.H.09	Hall	5 - 24 VDC	L0	316L SS	EPDM	IP68
F3.01.H.10	Hall	5 - 24 VDC	L0	316L SS	FPM	IP68
F3.01.H.11	Hall	5 - 24 VDC	L1	316L SS	EPDM	IP68
F3.01.H.12	Hall	5 - 24 VDC	L1	316L SS	FPM	IP68
F3.01.H.25	Hall	5 - 24 VDC	L0	BRASS	EPDM	IP68
F3.01.H.26	Hall	5 - 24 VDC	L0	BRASS	FPM	IP68
F3.01.H.27	Hall	5 - 24 VDC	L1	BRASS	EPDM	IP68
F3.01.H.28	Hall	5 - 24 VDC	L1	BRASS	FPM	IP68
F3.01.C.01	Coil	3 - 5 VDC	L0	C-PVC	EPDM	IP68
F3.01.C.02	Coil	3 - 5 VDC	L0	C-PVC	FPM	IP68
F3.01.C.03	Coil	3 - 5 VDC	L1	C-PVC	EPDM	IP68
F3.01.C.04	Coil	3 - 5 VDC	L1	C-PVC	FPM	IP68
F3.01.C.05	Coil	3 - 5 VDC	L0	PVDF	EPDM	IP68
F3.01.C.06	Coil	3 - 5 VDC	L0	PVDF	FPM	IP68
F3.01.C.07	Coil	3 - 5 VDC	L1	PVDF	EPDM	IP68
F3.01.C.08	Coil	3 - 5 VDC	L1	PVDF	FPM	IP68
F3.01.C.09	Coil	3 - 5 VDC	L0	316L SS	EPDM	IP68
F3.01.C.10	Coil	3 - 5 VDC	L0	316L SS	FPM	IP68
F3.01.C.11	Coil	3 - 5 VDC	L1	316L SS	EPDM	IP68
F3.01.C.12	Coil	3 - 5 VDC	L1	316L SS	FPM	IP68
F3.01.C.25	Coil	3 - 5 VDC	L0	BRASS	EPDM	IP68
F3.01.C.26	Coil	3 - 5 VDC	L0	BRASS	FPM	IP68
F3.01.C.27	Coil	3 - 5 VDC	L1	BRASS	EPDM	IP68
F3.01.C.28	Coil	3 - 5 VDC	L1	BRASS	FPM	IP68

Ordering Data

FlowX3 F3.15.H.XX (with O.C. output & MIN alarm)

Part No.	Version	Power supply	Length	Body	O-rings	Enclosure
F3.15.H.01	Hall	12 - 24 VDC	L0	C-PVC	EPDM	IP65
F3.15.H.02	Hall	12 - 24 VDC	L0	C-PVC	FPM	IP65
F3.15.H.03	Hall	12 - 24 VDC	L1	C-PVC	EPDM	IP65
F3.15.H.04	Hall	12 - 24 VDC	L1	C-PVC	FPM	IP65
F3.15.H.05	Hall	12 - 24 VDC	L0	PVDF	EPDM	IP65
F3.15.H.06	Hall	12 - 24 VDC	L0	PVDF	FPM	IP65
F3.15.H.07	Hall	12 - 24 VDC	L1	PVDF	EPDM	IP65
F3.15.H.08	Hall	12 - 24 VDC	L1	PVDF	FPM	IP65
F3.15.H.09	Hall	12 - 24 VDC	L0	316L SS	EPDM	IP65
F3.15.H.10	Hall	12 - 24 VDC	L0	316L SS	FPM	IP65
F3.15.H.11	Hall	12 - 24 VDC	L1	316L SS	EPDM	IP65
F3.15.H.12	Hall	12 - 24 VDC	L1	316L SS	FPM	IP65
F3.15.H.13	Hall	12 - 24 VDC	L0	BRASS	EPDM	IP65
F3.15.H.14	Hall	12 - 24 VDC	L0	BRASS	FPM	IP65
F3.15.H.15	Hall	12 - 24 VDC	L1	BRASS	EPDM	IP65
F3.15.H.16	Hall	12 - 24 VDC	L1	BRASS	FPM	IP65

FlowX3 F3.30.H.XX (with 4-20 mA output)

Part No.	Version	Power supply	Length	Body	O-rings	Enclosure
F3.30.H.01	Hall	12 - 24 VDC	L0	C-PVC	EPDM	IP65
F3.30.H.02	Hall	12 - 24 VDC	L0	C-PVC	FPM	IP65
F3.30.H.03	Hall	12 - 24 VDC	L1	C-PVC	EPDM	IP65
F3.30.H.04	Hall	12 - 24 VDC	L1	C-PVC	FPM	IP65
F3.30.H.05	Hall	12 - 24 VDC	L0	PVDF	EPDM	IP65
F3.30.H.06	Hall	12 - 24 VDC	L0	PVDF	FPM	IP65
F3.30.H.07	Hall	12 - 24 VDC	L1	PVDF	EPDM	IP65
F3.30.H.08	Hall	12 - 24 VDC	L1	PVDF	FPM	IP65
F3.30.H.09	Hall	12 - 24 VDC	L0	316L SS	EPDM	IP65
F3.30.H.10	Hall	12 - 24 VDC	L0	316L SS	FPM	IP65
F3.30.H.11	Hall	12 - 24 VDC	L1	316L SS	EPDM	IP65
F3.30.H.12	Hall	12 - 24 VDC	L1	316L SS	FPM	IP65
F3.30.H.13	Hall	12 - 24 VDC	L0	BRASS	EPDM	IP65
F3.30.H.14	Hall	12 - 24 VDC	L0	BRASS	FPM	IP65
F3.30.H.15	Hall	12 - 24 VDC	L1	BRASS	EPDM	IP65
F3.30.H.16	Hall	12 - 24 VDC	L1	BRASS	FPM	IP65

Ordering Data

Output devices

Part No.	Housing	Gaskets	Enclosure	Description
F3.K315	PVC	EPDM	IP65	Frequency Output & MIN Alarm KIT
F3.K330	PVC	EPDM	IP65	4-20 mA Output KIT

Spare Parts

Item	Part No.	Name	Description
A-1	F3.SP1	4 pole Cable Plug	Cable Plug according to DIN 43650
A-2	F3.SP2.1	Sensor Cap	Black Sensor Cap, for Hall version
A-2	F3.SP2.2	Sensor Cap	Red Sensor Cap, for Coil version
A-2	F3.SP2.5	Sensor Cap	Brass Sensor Cap, for Hall and Coil versions
A-2	F3.SP2.6	Sensor Cap	SS Sensor Cap, for Hall and Coil versions
A-3	F3.SP3.1	O-Rings	EPDM Sensor body O-rings
A-3	F3.SP3.2	O-Rings	FPM Sensor body O-rings
A-4	F3.SP4	Rotor KIT	ECTFE (Halar®) rotor with Ceramic Shaft and Bearings
A5	F3.SP4.2	Rotor KIT	ECTFE (Halar®) rotor with New Machined Ceramic Shaft and Bearings
	F3.SP5.1	Sensor Plug	CPVC Sensor Plug
	F3.SP5.2	Sensor Plug	PVDF Sensor Plug
	F3.SP5.3	Sensor Plug	Stainless Steel Sensor Plug
	F3.SP6	Electrical cable	Cable (per meter), 22AWG, 3 cond.
B-1	F3.SP7	PG11	PG11 Cable Gland for K315 or K330 Kit

